

# The Baseline Dichroism Spectroscopy

**A relatively new technique with a growing number of applications, dichroism spectroscopy is based upon the fact that a sample interacts with the same wavelength of light having different circular polarization in different ways.**

**David W. Ball**

In mineralogy, dichroism is the phenomenon in which a crystal has two different colors when viewed along different crystal axes (dichroism = “two-colored”). The semiprecious gemstone tourmaline might be the best-known example.

In spectroscopy, dichroism is a slightly different matter. But first, a little background information is in order.

Recall that while “regular” light has electric and magnetic field vectors that point in random directions perpendicular to its axis of travel (1, 2), there are ways we can generate light so that its electric (and magnetic) field vectors all point in the same direction. We say that this light is *linearly polarized*. Typically, linearly polarized light (also called *plane polarized light*) is represented by a series of parallel arrows, as shown in Figure 1.

In organic chemistry, we discuss the fact that enantiomers — that is, three-dimensional mirror-image molecules that cannot be superimposed on each other, much like our left and right hands — rotate the plane of polarized light in equal but opposite directions. The so-called *dextro* form of an enantiomer rotates polarized light to the right, as illustrated in Figure 2a, while the *levo* enantiomer rotates plane-polarized light to the left, as shown in Figure 2b.

There is another kind of polarization of light, called *circular polarization*. In this case, the light vector propagates as a helix, as shown in Figure 3, from both a side view and an end view. The helix can be right-handed or left-handed, so we can have right-circularly polarized light and left-circularly polarized light.

**David Ball** is a professor of Chemistry at Cleveland State University in Ohio. Many of his “Baseline” columns have been reprinted in book form by SPIE Press as *The Basics of Spectroscopy*, available through the

SPIE Web Bookstore at [www.spie.org](http://www.spie.org). His new textbook, *Physical Chemistry*, was published in August 2002. He can be reached at the Department of Chemistry, Cleveland State University, Cleveland, OH 44115, by e-mail at [d.ball@csuohio.edu](mailto:d.ball@csuohio.edu), or by phone at (216) 687-2456. His personal Web site is: [academic.csuohio.edu/ball](http://academic.csuohio.edu/ball).

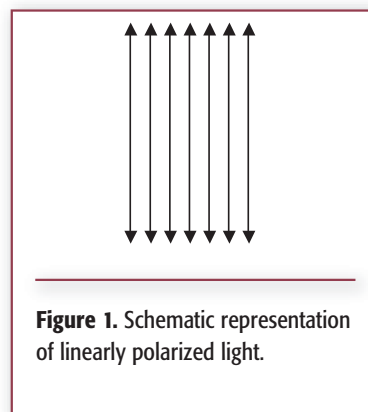

**Figure 1.** Schematic representation of linearly polarized light.

How is circular polarized light generated? It's not as simple as passing randomly orientated light through a polarizer. We start with light that has been polarized at a 45° angle. This light can be thought of as half *x*-polarized light and half *y*-polarized light (Figure 4).

Next, we pass this

light through what is called a quarter-wave plate. A quarter-wave plate is a birefringent material (such as mica or quartz) (3) that has a slightly different index of refraction in one dimension than in another. When properly oriented with the incoming light, either the *x*-component or the *y*-component of the 45°-polarized light will be slowed slightly with respect to the other. (Recall that the index of refraction is a measure of how fast light travels in a medium.) If the quarter-wave plate is the correct thickness, one component of the light will be retarded one-quarter of a wavelength behind the other component. When the two components recombine upon leaving the plate, the resulting light vector rotates in a spiral, giving circular polarized light. Circular polarized light can be thought of as the proper combination of two linearly polarized lights (just as linearly polarized light can be thought of as the proper combination of left- and right-circularly polarized light). If the original *x*- and *y*-components of the incoming light have different intensities, the result is elliptical polarized light — circular polarized light being a special case of elliptical polarized light where the two components of incoming light have the same intensity.

Circular polarized light is useful in spectroscopy because in some circumstances, right-circularly polarized light is absorbed in different amounts than left-circularly polarized light. This differential in absorption of circular polarized light gives rise to *dichroism spectroscopy*. Thus, dichroism spectroscopy is based upon the fact that a sample interacts

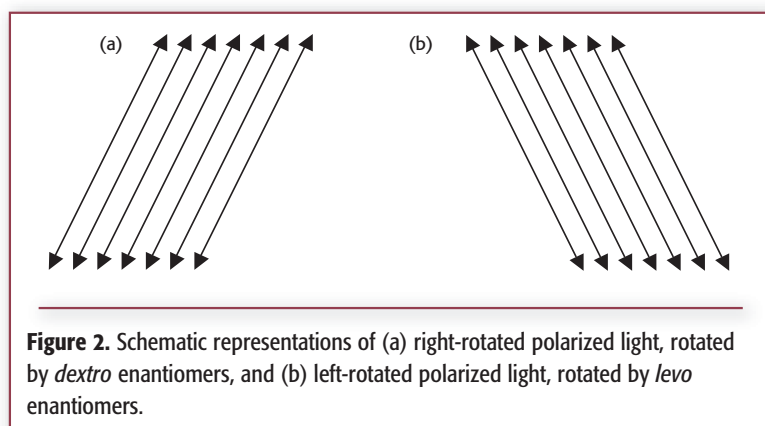

**Figure 2.** Schematic representations of (a) right-rotated polarized light, rotated by *dextro* enantiomers, and (b) left-rotated polarized light, rotated by *levo* enantiomers.

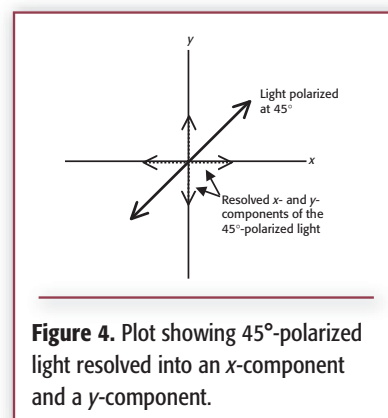

**Figure 4.** Plot showing 45°-polarized light resolved into an x-component and a y-component.

with the same wavelength of light but with different circular polarization in a different way. Most circular dichroic (CD) spectra are difference spectra.

There are at least three major areas of application in dichroism spectroscopy (also called CD spectroscopy):

**Analysis of chiral molecules.** Chiral molecules rotate the plane of linearly polarized light because they absorb preferentially either left-circularly or right-circularly polarized light. It might be only one part in a thousand or less, but that is enough for the right optics to note a difference in the absorption. In the field of biochemistry, the secondary structures of proteins (the alpha helices and beta sheets, for example) interact preferentially with one circular polarization, allowing one to follow changes in protein structure using dichroism spectroscopy (in this application, also called electronic circular dichroism). As yet, there is no known direct connection between a CD spectrum and a particular structural feature of a protein, but a protein's characteris-

tic CD spectrum can be used to follow any changes (or lack of) in the protein's structure.

**Vibrational circular dichroism.** The vibrations of chiral molecules selectively absorb circularly polarized light. The effect usually is several orders of magnitude lower than (electric) circular dichroism, but high-sensitivity techniques such as Fourier transform infrared spectroscopy can make up for this deficiency. A difference in the absorption of different circular polarized light by vibrations is caused by an interaction between the vibrational electronic and magnetic dipole transition moments (4). Because this interaction is not seen when one uses the Born–Oppenheimer (BO) approximation, calculation of vibrational circular dichroism (VCD) is complex because both electronic and vibrational behavior of a molecule must be treated together (not separately, as the BO approximation allows). The ability to calculate VCD effects has been available since about 1998, greatly enhancing the

applicability of this spectroscopic technique. Enantiomers of chiral compounds exhibit the same magnitude but opposite VCD spectra. Combinations of calculated and measured VCD spectra are useful in determining the absolute stereochemistry of chiral compounds. Figure 5 shows an example of a VCD spectrum of two enantiomers of the same compound.

**Magnetic circular dichroism.** One form of spectroscopy is based upon the fact that there is a difference in selection rules for left-circularly polarized (LCP) light and right-circularly polarized (RCP) light. For LCP light, the selection rule is

$$\Delta J = +1$$

whereas for RCP light, the selection rule is

$$\Delta J = -1$$

In the presence of a magnetic field, degenerate (same-energy) atomic or

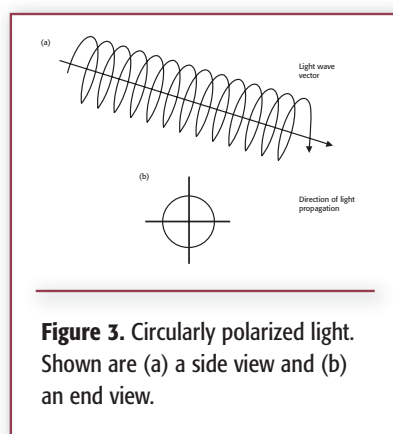

**Figure 3.** Circularly polarized light. Shown are (a) a side view and (b) an end view.

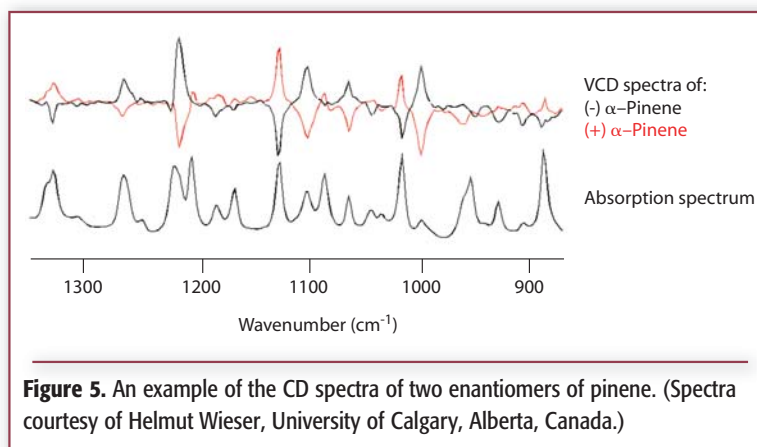

**Figure 5.** An example of the CD spectra of two enantiomers of pinene. (Spectra courtesy of Helmut Wieser, University of Calgary, Alberta, Canada.)

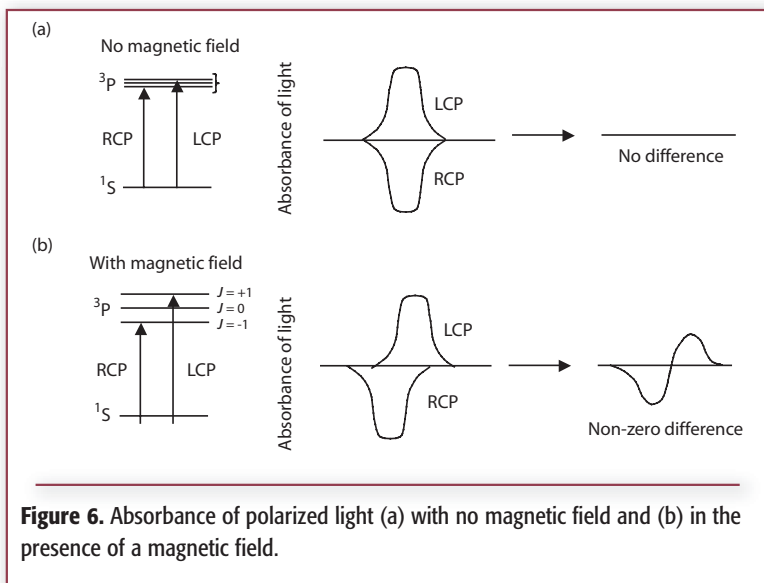

**Figure 6.** Absorbance of polarized light (a) with no magnetic field and (b) in the presence of a magnetic field.

ionic energy levels split according to the value of the  $J$  quantum number. This is known as the Zeeman effect. Without the presence of a magnetic field, both LCP and RCP light absorb at the same energy, and the difference between the absorptions is zero. This is illustrated in Figure 6a. In the presence of a magnetic

field, however, the energy changes that accompany the absorption of RCP and LCP lights change slightly, as shown in Figure 6b. (The scales have been exaggerated for purposes of illustration.) Now, the difference between the LCP and RCP light absorption shows a distinctive curve, and a magnetic circular

dichroism (MCD) spectrum is produced. The exact shape of an MCD signal depends upon the degeneracies of the original energy levels; in Figure 6b, the MCD signal demonstrated is called an A term. Interested readers are directed toward a monograph on MCD spectroscopy (5).

Clearly, dichroism spectroscopy is a useful form of spectroscopy that is receiving more attention as the field develops.

## References

1. D.W. Ball, *Spectroscopy* **9**(5), 24 (1995).
2. D.W. Ball, *Spectroscopy* **9**(6), 20 (1995).
3. Melles Griot, Inc., website: [www.mellesgriot.com](http://www.mellesgriot.com). Accessed August 30, 2004.
4. P.J. Stephens, *J. Phys. Chem.* **89**, 748 (1985).
5. S.B. Piepho and P.N. Schatz, *Group Theory in Spectroscopy With Applications to Magnetic Circular Dichroism* (Wiley Interscience, New York, 1983). ■